

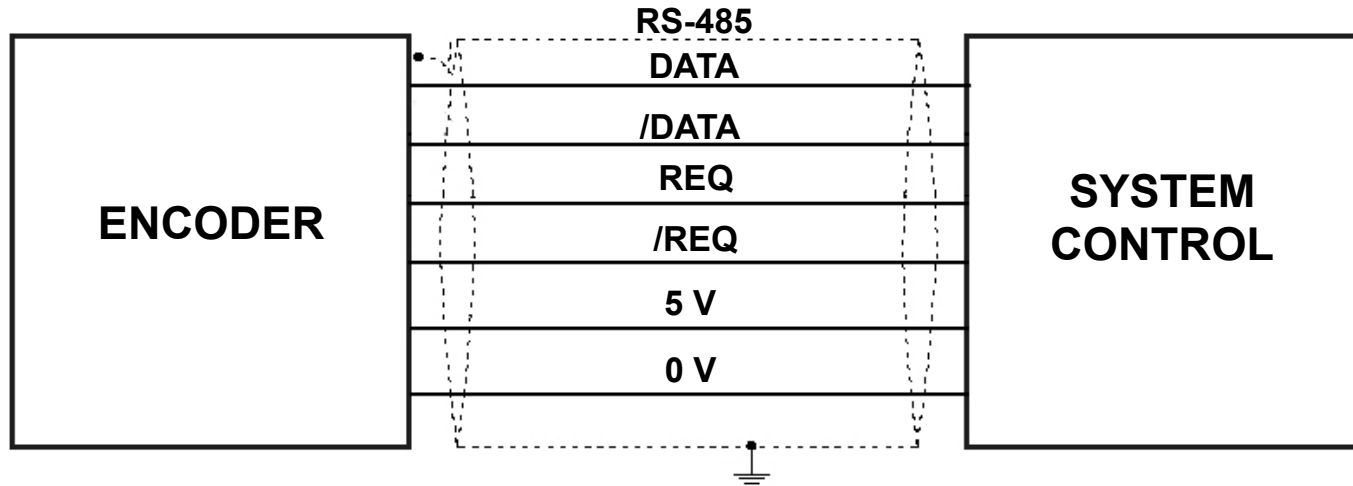

LAD

Características eléctricas – Electrical characteristics

	LAD 50	LAD10
Resolución <i>Resolution</i>	50 nm	10 nm
Alimentación <i>Power supply</i>	5 V ± 10%, 250 mA	
Conexión <i>Connection</i>	Con conector incorporado <i>With built-in connector</i>	
Longitud de cable <i>Cable length</i>	100 m	300 feet



CABLES PARA CONEXIÓN DIRECTA DE ENCODERS ABSOLUTOS FAGOR A OTROS CONTROLADORES
CABLES FOR DIRECT CONNECTION OF FAGOR ABSOLUTE ENCODERS TO OTHER CNCs

HASTA 9 METROS - UP TO 9 METERS

EC -...PA - O							
Sin conector en uno de los extremos; para otras aplicaciones. En longitudes de 1, 3, 6 y 9 metros. <i>Without a connector at one end; for other applications. Available in 1, 3, 6 and 9 meters</i>							
SEÑAL / SIGNAL	DATA	/ DATA	REQ	/ REQ	+5 V	0V	Tierra / Ground
COLOR	Verde <i>Green</i>	Amarillo <i>Yellow</i>	Azul <i>Blue</i>	Rojo <i>Red</i>	Marrón + Gris <i>Brown + Grey</i>	Blanco + Rosa <i>White + Pink</i>	Malla / Shield

A PARTIR DE 9 METROS - FROM 9 METERS

*(EC- ...B - C9) + (XC - C8 - ... - O)

EC -...B - C9										
Conector Circular 17 macho. En longitudes de 1 y 3 metros (otras longitudes consultar a Fagor). <i>Circular 17 male connector . Available in 1 and 3 meters (contact Fagor for other lengths).</i>										
PIN	14	17	8	9	7	1	10	4	11	Carcasa / Housing
SEÑAL / SIGNAL	DATA	/ DATA	REQ	/ REQ	+5 V	+5 V sensor	0V	0V sensor	Tierra / Ground	Tierra / Ground
COLOR	Gris <i>Grey</i>	Rosa <i>Pink</i>	Negro <i>Black</i>	Violeta <i>Purple</i>	Marrón <i>Brown</i>	Verde Claro <i>Light Green</i>	Blanco <i>White</i>	Naranja <i>Orange</i>	Malla interna <i>Internal shield</i>	Malla externa <i>External shield</i>

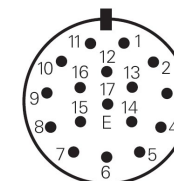

EC - ...B - C9

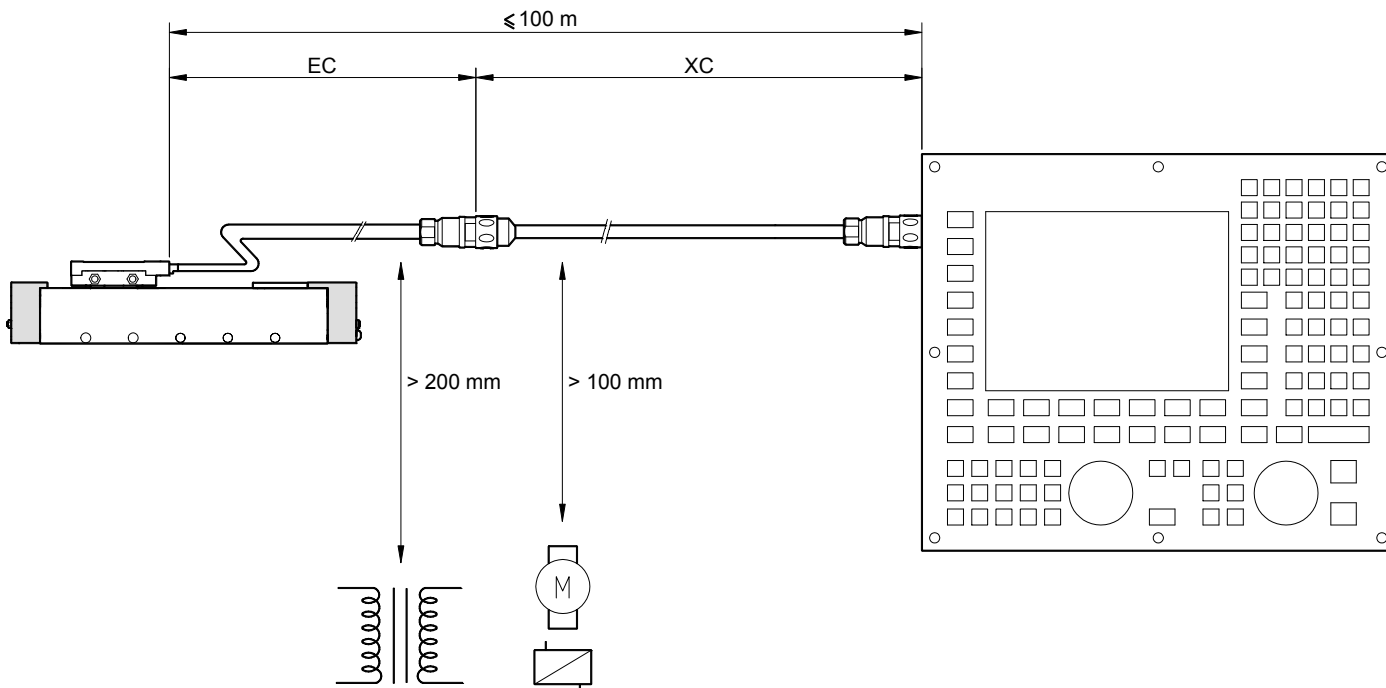

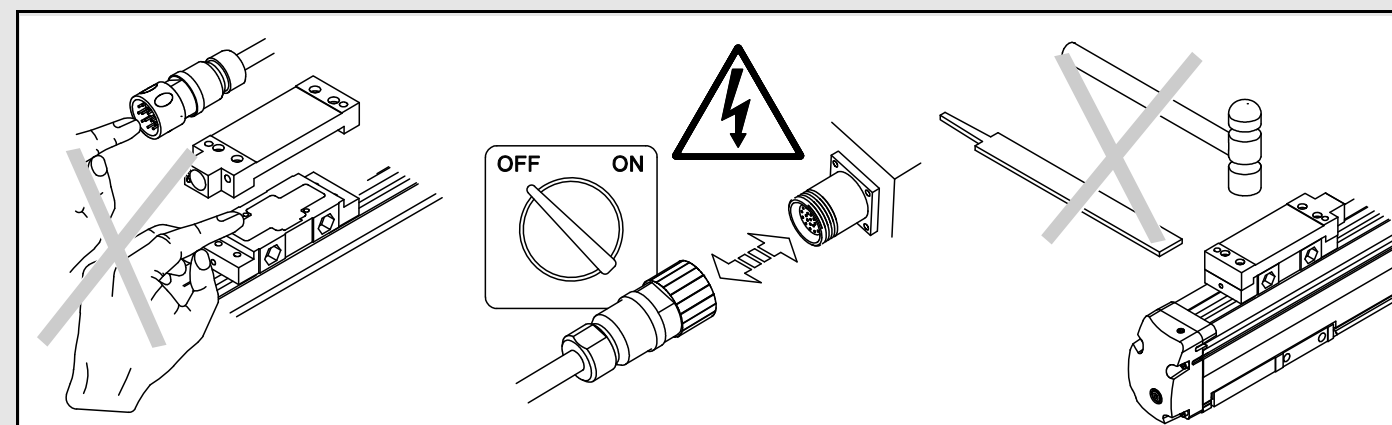

Es posible orientar la salida del conector a ambos lados.
The connector exit may be oriented at both ends.

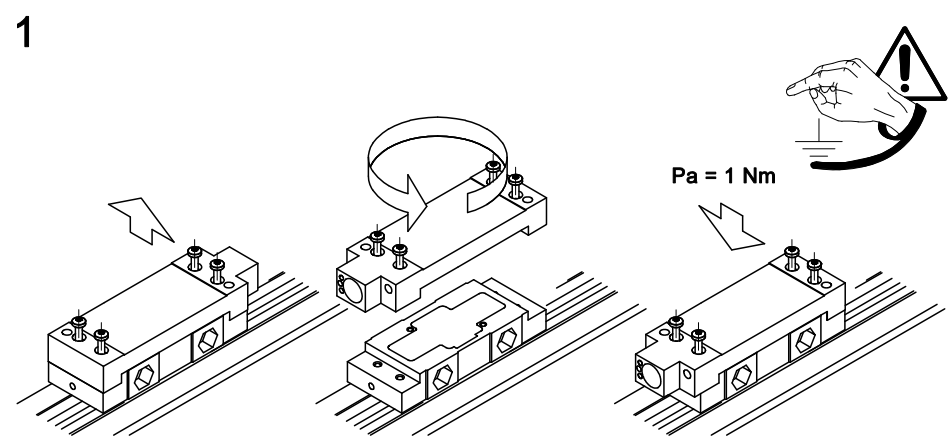

Introducir la cabeza por cualquiera de los dos extremos de la regla.
Insert the reader head through any of the two ends of the scale.

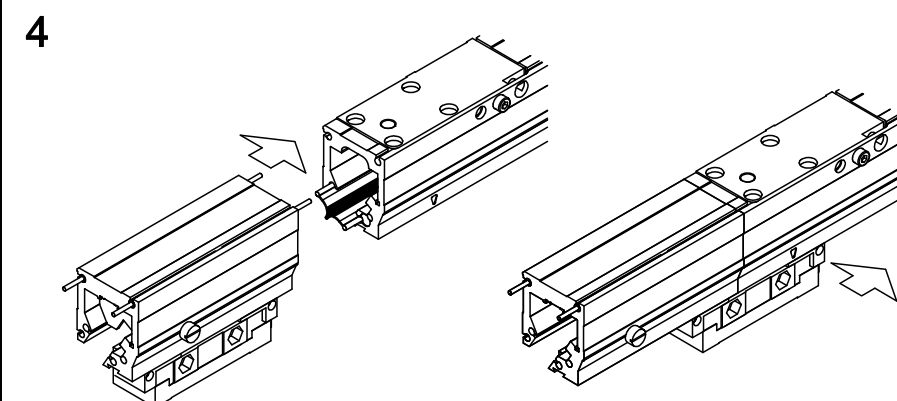

Quitar las tapas.
Remove the end caps.

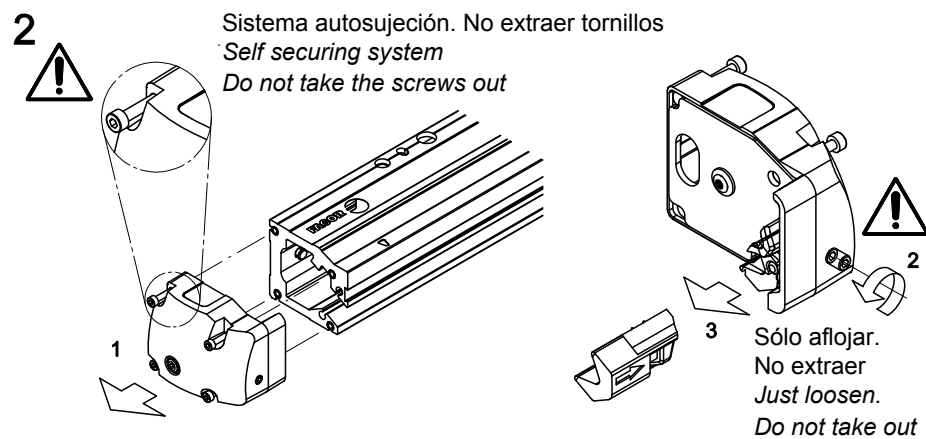

Fijar la cabeza lectora.
 Los soportes fijan la distancia de separación (2.5 mm) entre la cabeza y la regla.
 Quitar los soportes de la cabeza.
Secure the reader head. The supports set the 2.5 mm gap between the reader head and the scale. Remove the reader head supports.

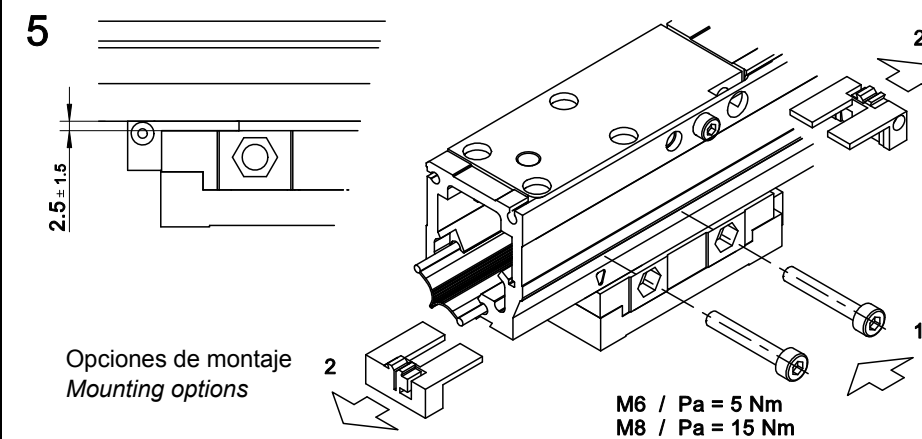

Aflojar los tornillos del embalaje de la cabeza.
Loosen the packing screws of the reader head.

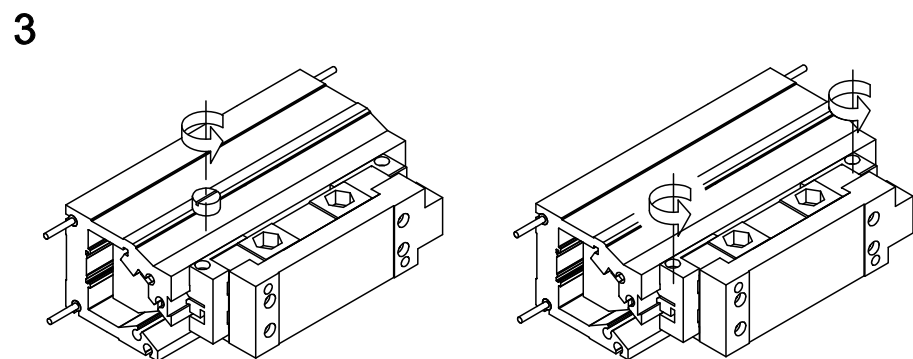

Poner las tapas.
Mount the end caps.

